

52+26

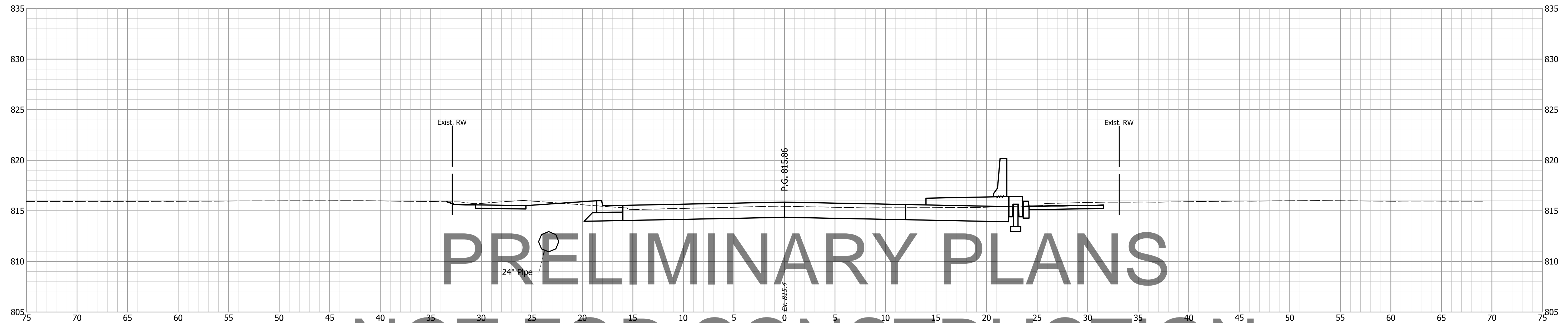

PRELIMINARY PLANS
NOT FOR CONSTRUCTION

52+00

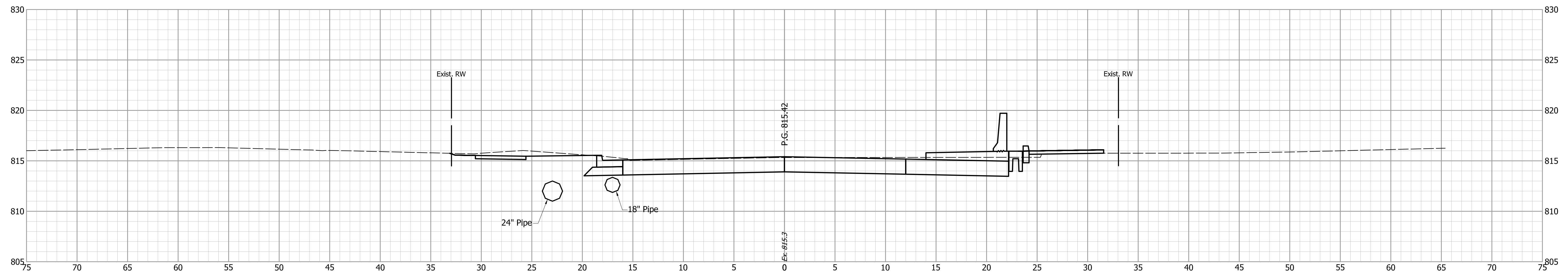

**NOT FOR
CONSTRUCTION**

DESIGNED: _____	PEC	DRAWN: _____	PEC
CHECKED: _____	GRW	CHECKED: _____	GRW

**INDIANA
DEPARTMENT OF TRANSPORTATION**

**CROSS SECTIONS
LINE "C"**

HORIZONTAL SCALE	BRIDGE FILE
1" = 5'	
VERTICAL SCALE	DESIGNATION
1" = 5'	1801912
SURVEY BOOK	SHEETS
	75 of 128
CONTRACT	PROJECT
B-41844	1801912

S:\2019\proj\2019-0103_LaPorte Railroad Trac_Renewal\Bids_Plan\Road Plans\1-Cross Sections\2019-0103-Cross Sections\01-Line-C\wg_Section_Sheet_003_8/4/2021_1:46:48 PM

54+50

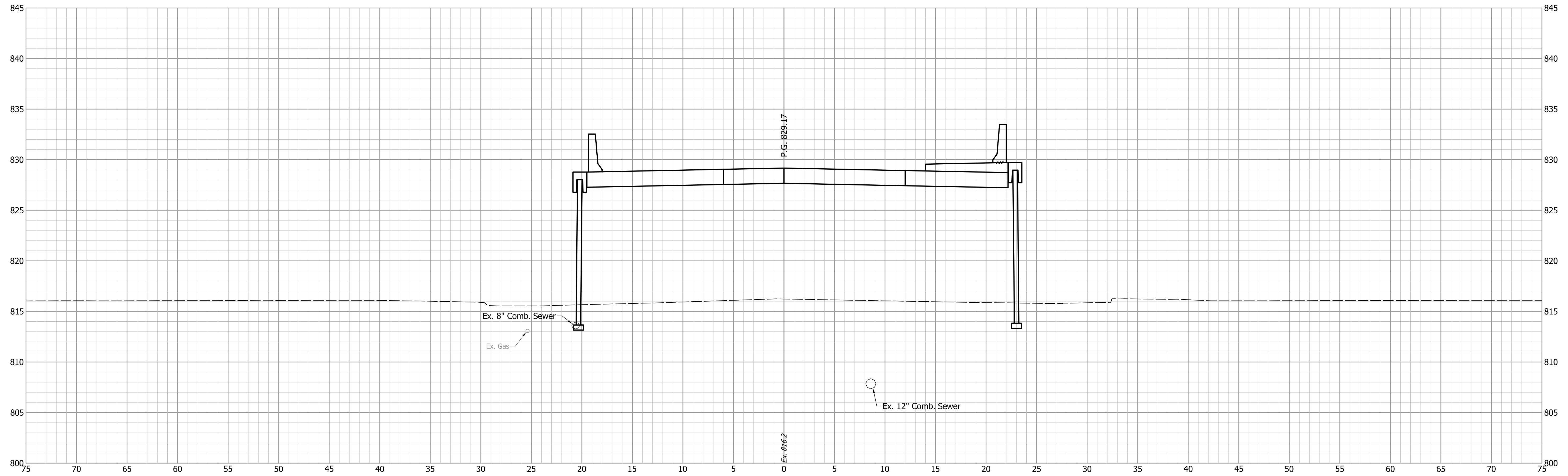

54+10

PRELIMINARY PLANS
NOT FOR CONSTRUCTION

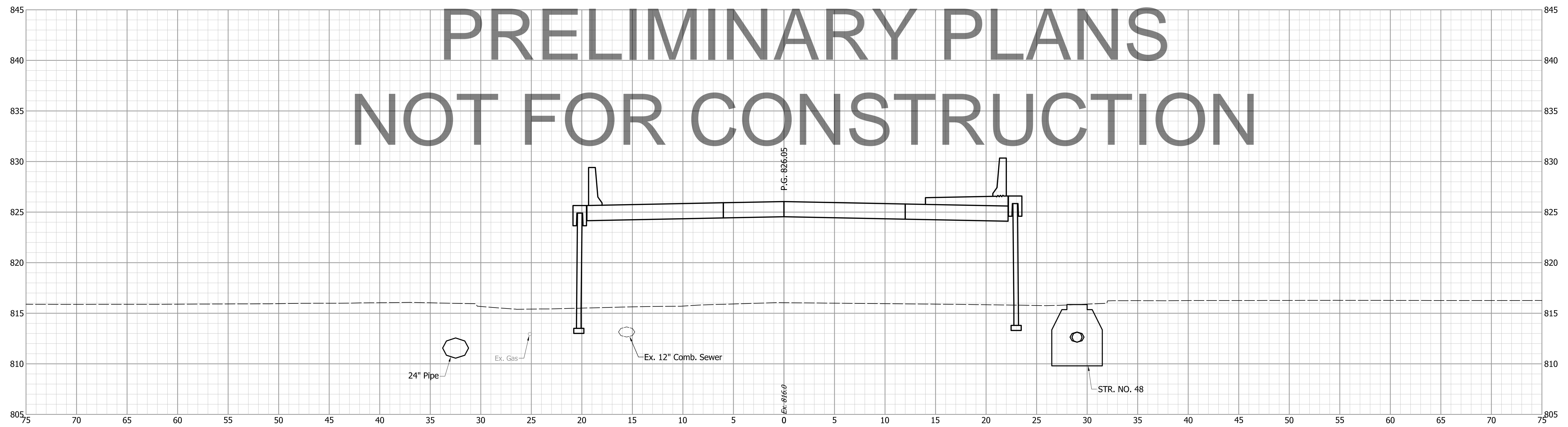

NOT FOR
CONSTRUCTION

DESIGNED: PEC DRAWN: PEC
 CHECKED: GRW CHECKED: GRW

INDIANA
DEPARTMENT OF TRANSPORTATION

CROSS SECTIONS
LINE "C"

HORIZONTAL SCALE 1" = 5'	BRIDGE FILE
VERTICAL SCALE 1" = 5'	DESIGNATION 1801912
SURVEY BOOK	SHEETS
CONTRACT B-41844	78 of 128 PROJECT 1801912

S:\2019\10-0103 Laphorte Railroad Trac. Bridge\Bridg. Plans\Road Plans\17-Cross Sections\2019-0103-Cross Sections\01-Line-C\wg. Section Sheet - 010 - 8/4/2021 1:45:57 PM

END PAVING EXCEPTION
STA. 57+90.74 'C'

57+65

PRELIMINARY PLANS
NOT FOR CONSTRUCTION

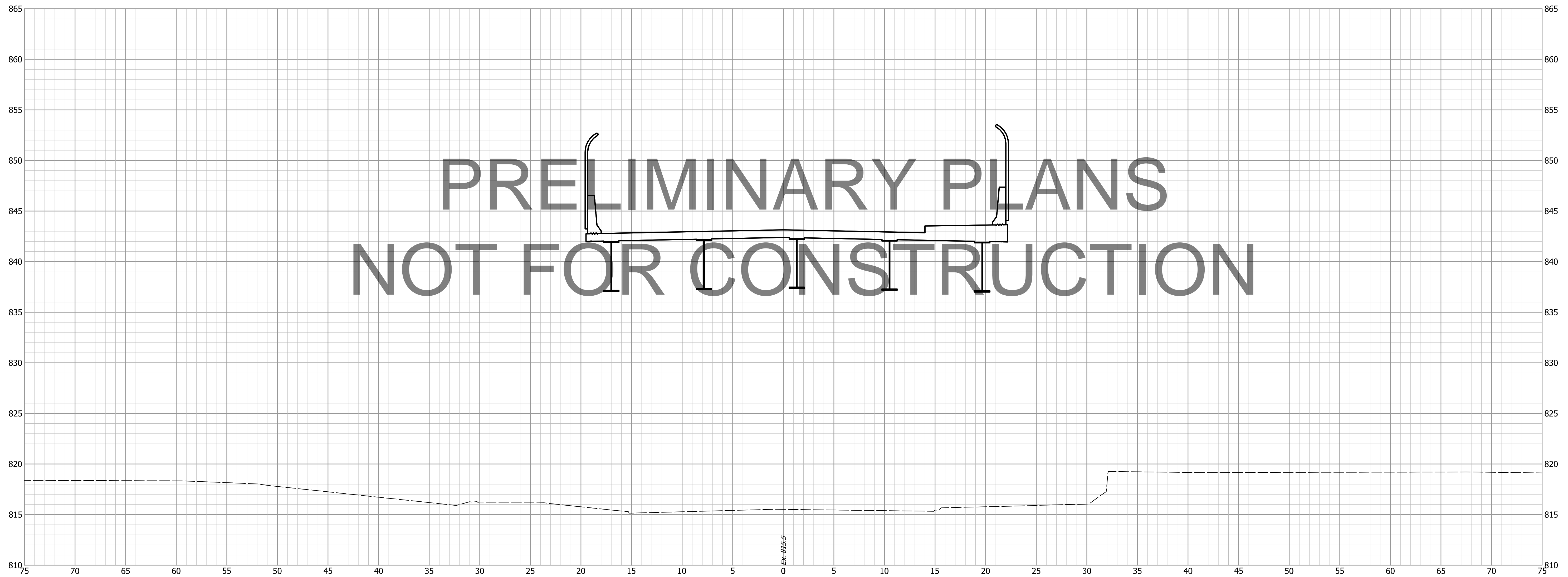

NOT FOR
CONSTRUCTION

DESIGNED: PEC DRAWN: PEC
CHECKED: GRW CHECKED: GRW

INDIANA
DEPARTMENT OF TRANSPORTATION

CROSS SECTIONS
LINE "C"

HORIZONTAL SCALE 1" = 5'	BRIDGE FILE
VERTICAL SCALE 1" = 5'	DESIGNATION 1801912
SURVEY BOOK	SHEETS
CONTRACT B-41844	87 of 128 PROJECT 1801912

47+32

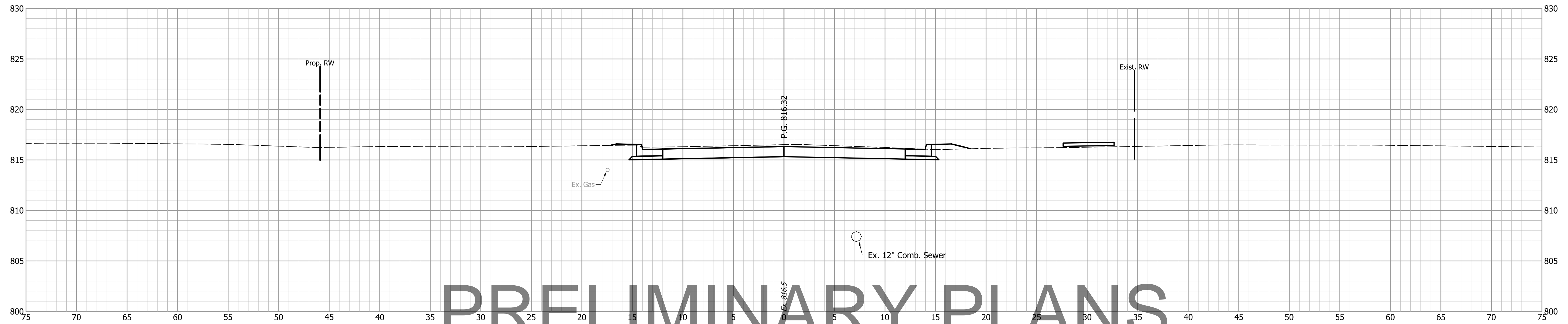

PRELIMINARY PLANS
NOT FOR CONSTRUCTION

47+00

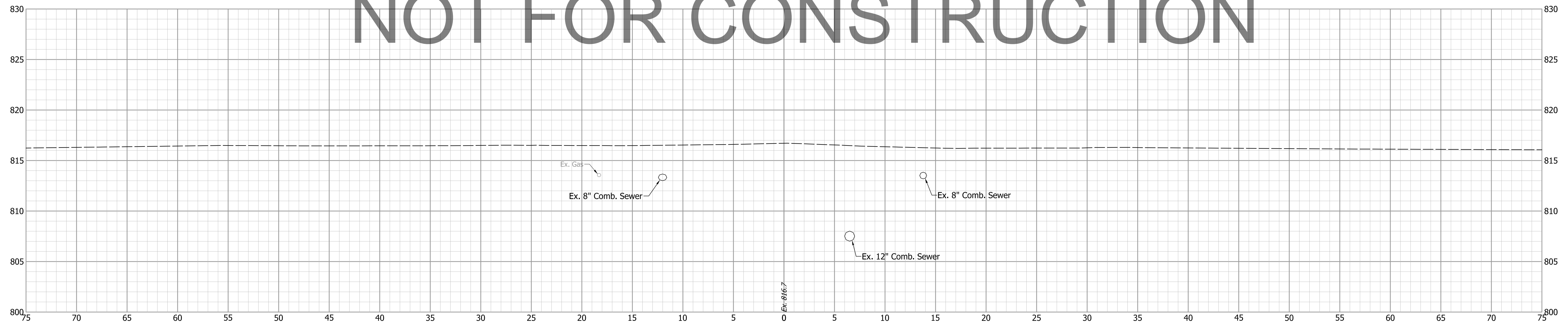

NOT FOR CONSTRUCTION

DESIGNED: _____ PEC	DRAWN: _____ PEC
CHECKED: _____ GRW	CHECKED: _____ GRW

INDIANA
DEPARTMENT OF TRANSPORTATION

CROSS SECTIONS
LINE "PR-2"

HORIZONTAL SCALE 1" = 5'	BRIDGE FILE
VERTICAL SCALE 1" = 5'	DESIGNATION 1801912
SURVEY BOOK	SHEETS
CONTRACT B-41844	94 of 128 PROJECT 1801912

S:\2019\10\10-0103 Laborte Railroad Trac_Renewal\Bids_Plan\Road Plans\1-Cross Sections\2019-0103-Cross Sections\01-Line PR-2.dwg Section Sheet - (2), 8/4/2021 2:46:16 PM

51+09

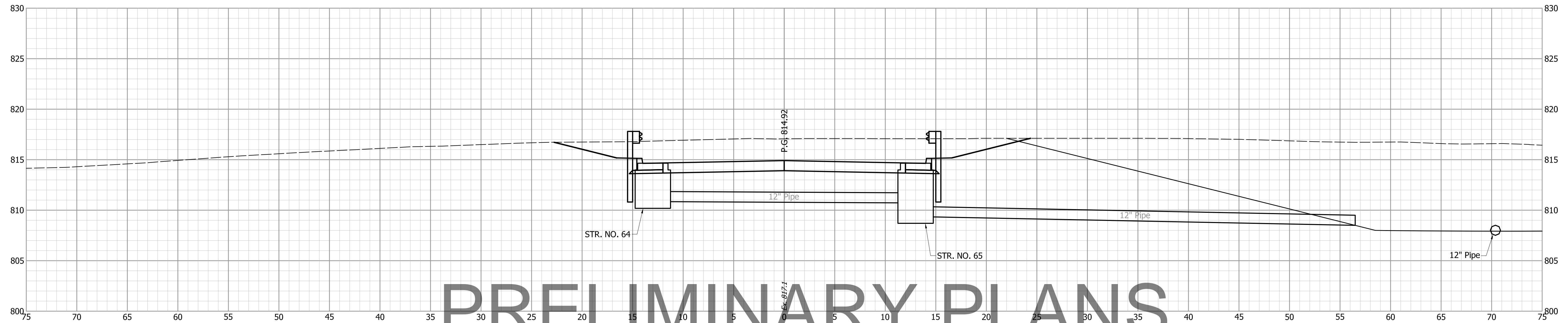

PRELIMINARY PLANS
NOT FOR CONSTRUCTION

51+00

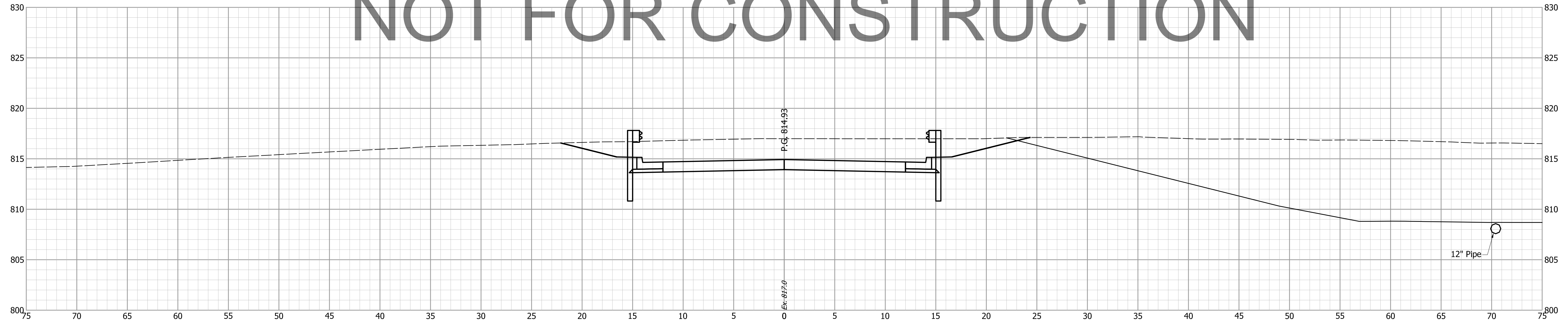

NOT FOR CONSTRUCTION

DESIGNED: PEC DRAWN: PEC
CHECKED: GRW CHECKED: GRW

INDIANA
DEPARTMENT OF TRANSPORTATION

CROSS SECTIONS
LINE "PR-2"

HORIZONTAL SCALE 1" = 5'	BRIDGE FILE
VERTICAL SCALE 1" = 5'	DESIGNATION 1801912
SURVEY BOOK	SHEETS
CONTRACT B-41844	100 of 128 PROJECT 1801912

53+00

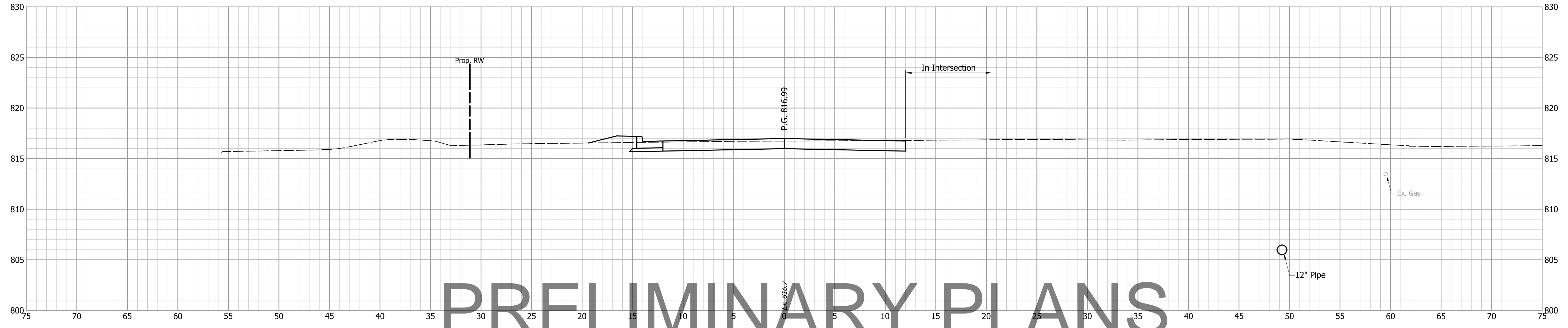

**PRELIMINARY PLANS
NOT FOR CONSTRUCTION**

52+50

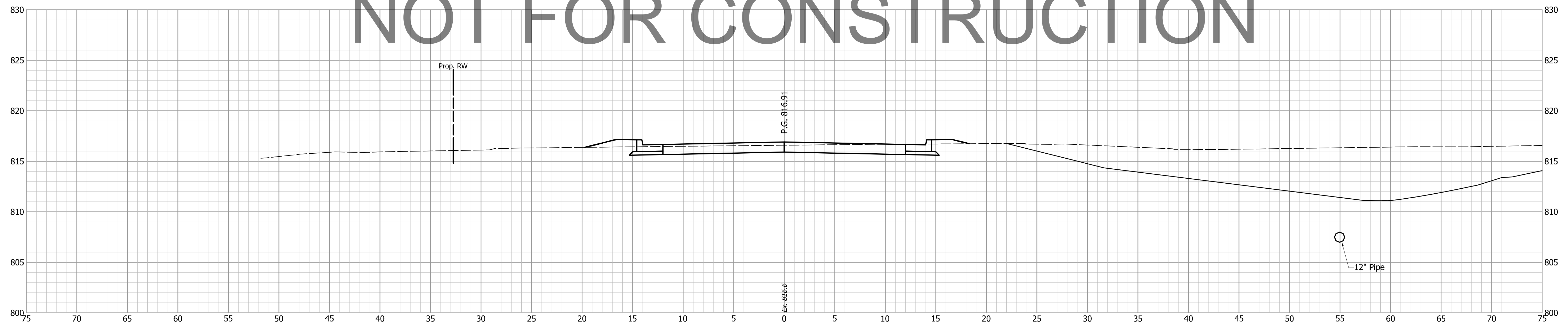

**NOT FOR
CONSTRUCTION**

DESIGNED: _____	PEC	DRAWN: _____	PEC
CHECKED: _____	GRW	CHECKED: _____	GRW

**INDIANA
DEPARTMENT OF TRANSPORTATION**

**CROSS SECTIONS
LINE "PR-2"**

HORIZONTAL SCALE	BRIDGE FILE
1" = 5'	
VERTICAL SCALE	DESIGNATION
1" = 5'	1801912
SURVEY BOOK	SHEETS
	102 of 128
CONTRACT	PROJECT
B-41844	1801912

47+58

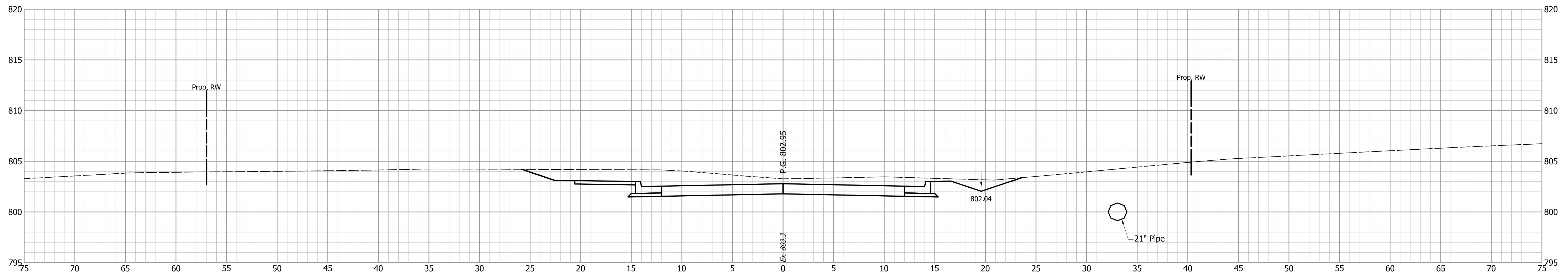

47+49

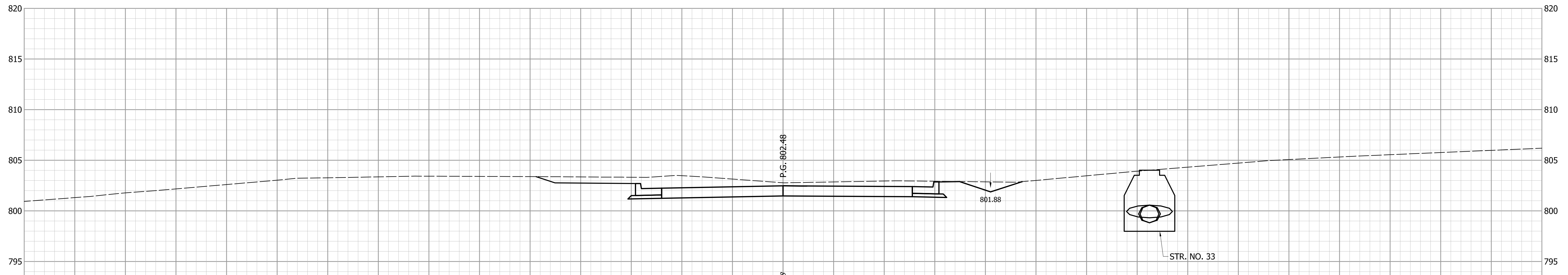

PRELIMINARY PLANS

47+43

NOT FOR CONSTRUCTION

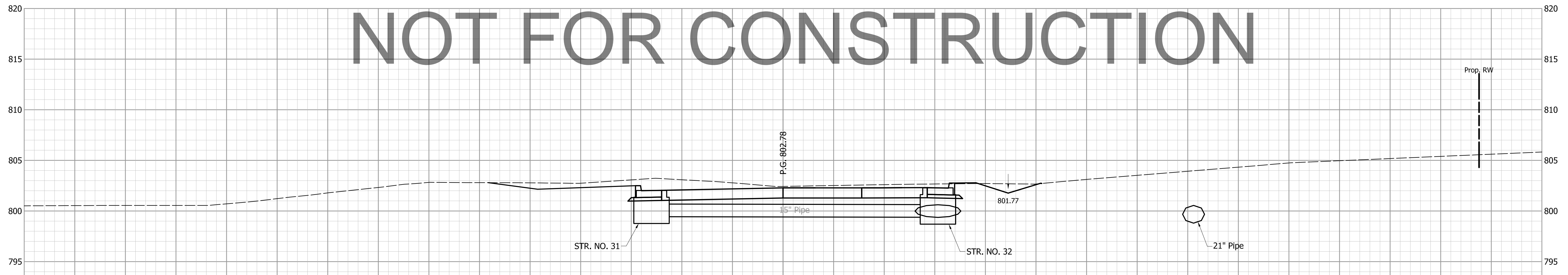

BEGIN CONSTRUCTION
STA. 47+08.89 LINE "S-1-C"

NOT FOR CONSTRUCTION

DESIGNED: _____	PEC	DRAWN: _____	PEC
CHECKED: _____	GRW	CHECKED: _____	GRW

INDIANA
DEPARTMENT OF TRANSPORTATION

CROSS SECTIONS
LINE "S-1-C" & "PR-1"

HORIZONTAL SCALE 1" = 5'	BRIDGE FILE
VERTICAL SCALE 1" = 5'	DESIGNATION 1801912
SURVEY BOOK	SHEETS 105 of 128
CONTRACT B-41844	PROJECT 1801912

S:\2019\19-0103 Labette Railroad Trm Rels\Bldg Plans\Road Plans\1-Cross Sections\2019-0103-Cross-Sections-01-Final.dwg, Section Sheet: (7), 8/4/2021, 2:28:14 PM

48+50

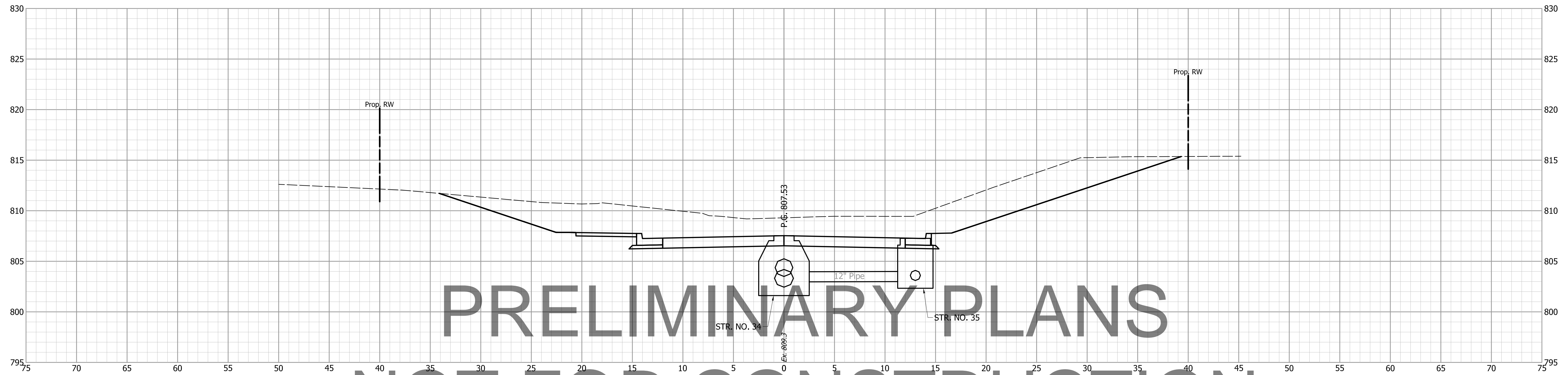

PRELIMINARY PLANS
NOT FOR CONSTRUCTION

48+00

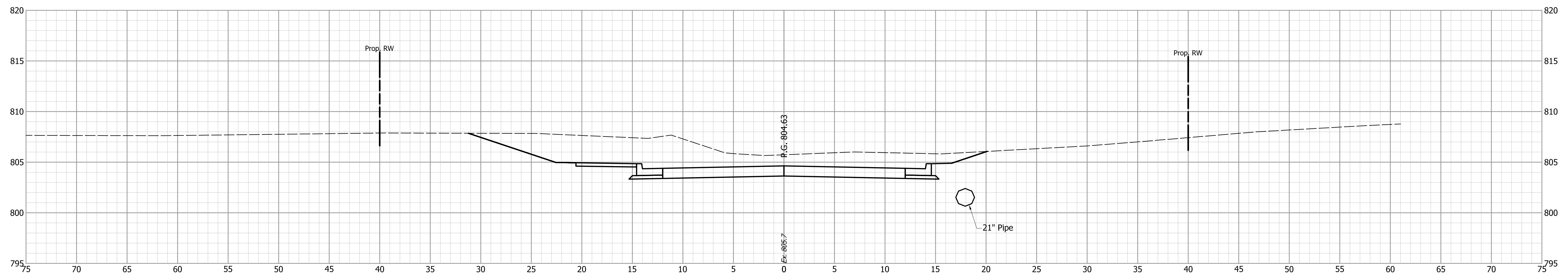

NOT FOR CONSTRUCTION

DESIGNED: _____	PEC	DRAWN: _____	PEC
CHECKED: _____	GRW	CHECKED: _____	GRW

INDIANA
DEPARTMENT OF TRANSPORTATION

CROSS SECTIONS
LINE "S-1-C" & "PR-1"

HORIZONTAL SCALE 1" = 5'	BRIDGE FILE
VERTICAL SCALE 1" = 5'	DESIGNATION 1801912
SURVEY BOOK	SHEETS 106 of 128
CONTRACT B-41844	PROJECT 1801912

END CONSTRUCTION
 STA. 51+00 LINE "D"=
 STA. 51+00.68 LINE "PR-1"

51+00

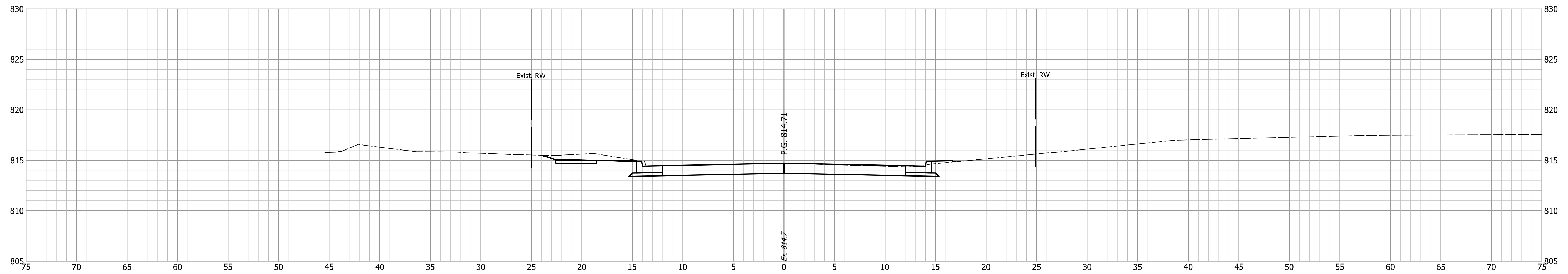

50+42

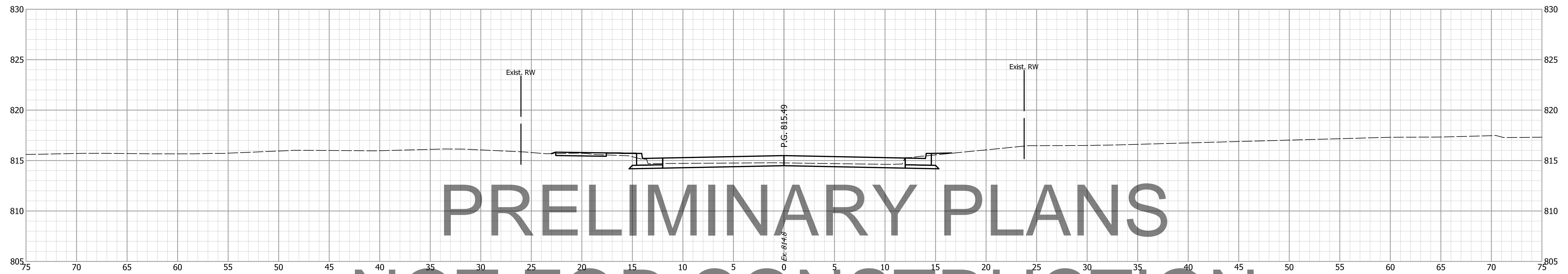

PRELIMINARY PLANS
 NOT FOR CONSTRUCTION

50+00

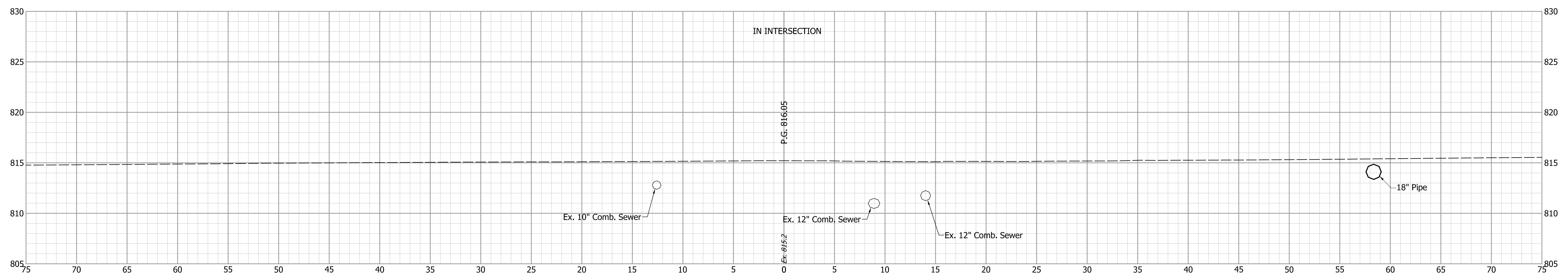

IN INTERSECTION

S:\2019\proj\2019-0103_Lafayette Railroad Trac_Road\Bldg_Plan\Road_Plan\17-Cross_Section\2019-0103-Cross_Section-01-Final.dwg, Section Sheet: (10), 8/4/2021 2:28:56 PM

NOT FOR
 CONSTRUCTION

DESIGNED: PEC DRAWN: PEC
 CHECKED: GRW CHECKED: GRW

INDIANA
 DEPARTMENT OF TRANSPORTATION

CROSS SECTIONS
 LINE "S-1-C" & "PR-1"

HORIZONTAL SCALE 1" = 5'	BRIDGE FILE
VERTICAL SCALE 1" = 5'	DESIGNATION 1801912
SURVEY BOOK	SHEETS 108 of 128
CONTRACT B-41844	PROJECT 1801912

56+50

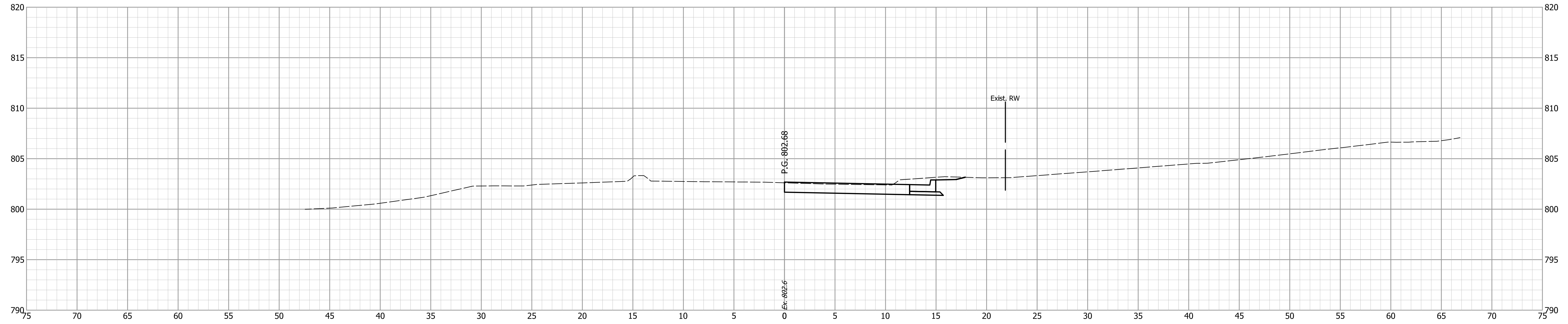

BEGIN CONSTRUCTION
STA. 56+00.00 LINE "F"

56+00

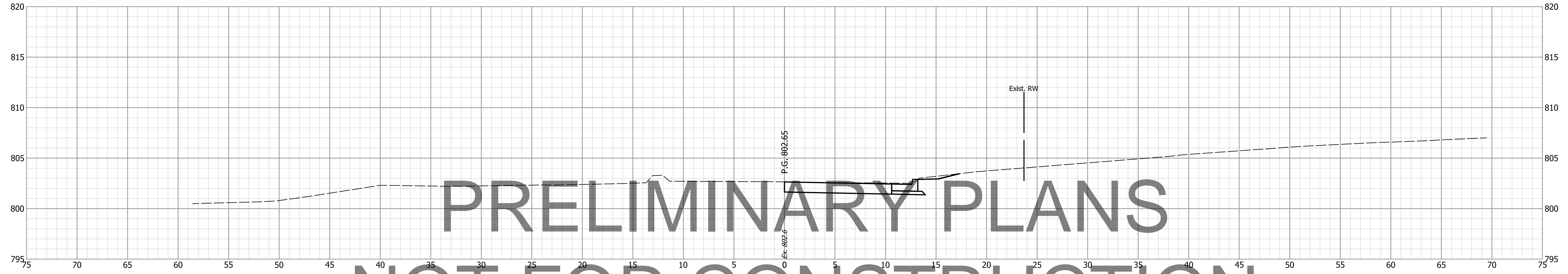

55+50

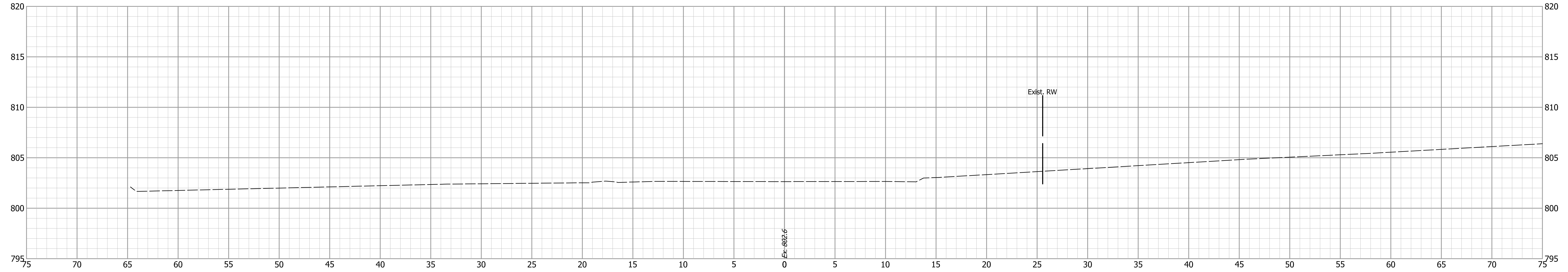

NOT FOR
CONSTRUCTION

DESIGNED: _____	PEC	DRAWN: _____	PEC
CHECKED: _____	GRW	CHECKED: _____	GRW

**INDIANA
DEPARTMENT OF TRANSPORTATION**

**CROSS SECTIONS
LINE "F"**

HORIZONTAL SCALE 1" = 5'	BRIDGE FILE
VERTICAL SCALE 1" = 5'	DESIGNATION 1801912
SURVEY BOOK	SHEETS
CONTRACT B-41844	109 of 128 PROJECT 1801912

S:\2019\proj\2019-0103 Labette Railroad Trac Enhance\bridge Plans\Road Plans\1-Cross Sections\2019-0103-Cross Sections-04-Line-F.dwg, Section Sheet - (14), 8/4/2021, 3:22:45 PM

57+50

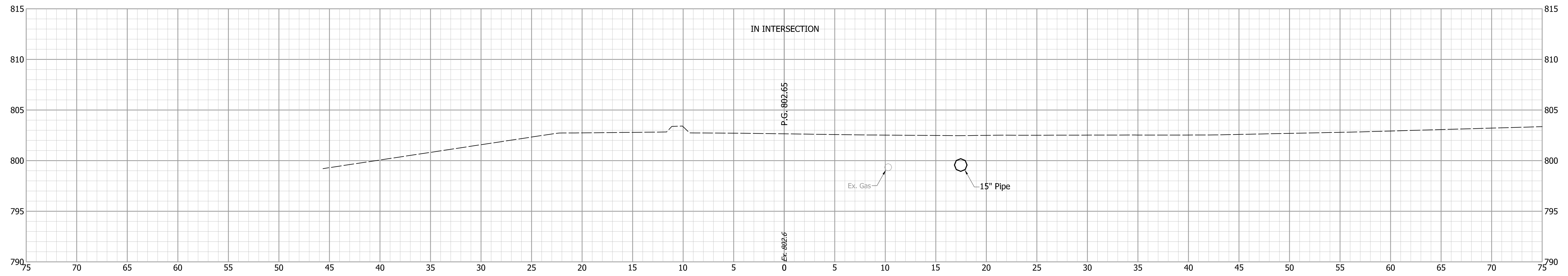

57+06

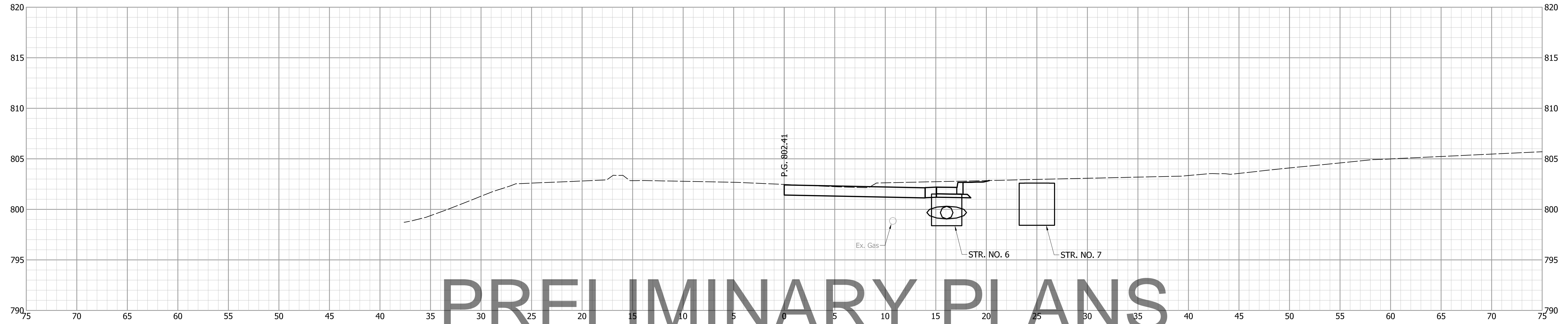

**PRELIMINARY PLANS
NOT FOR CONSTRUCTION**

57+00

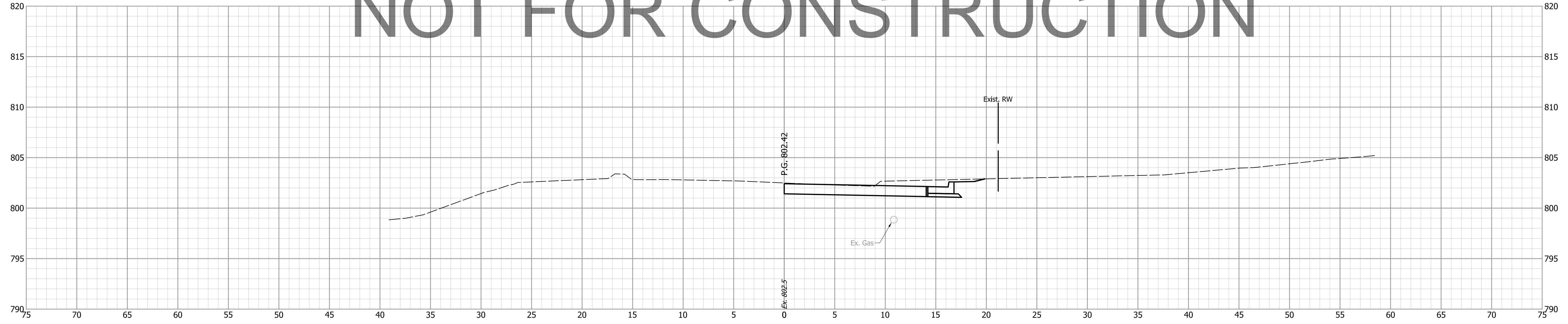

**NOT FOR
CONSTRUCTION**

DESIGNED: PEC DRAWN: PEC
CHECKED: GRW CHECKED: GRW

INDIANA
DEPARTMENT OF TRANSPORTATION

CROSS SECTIONS
LINE "F"

HORIZONTAL SCALE	BRIDGE FILE
1" = 5'	
VERTICAL SCALE	DESIGNATION
1" = 5'	1801912
SURVEY BOOK	SHEETS
	110 of 128
CONTRACT	PROJECT
B-41844	1801912

60+00

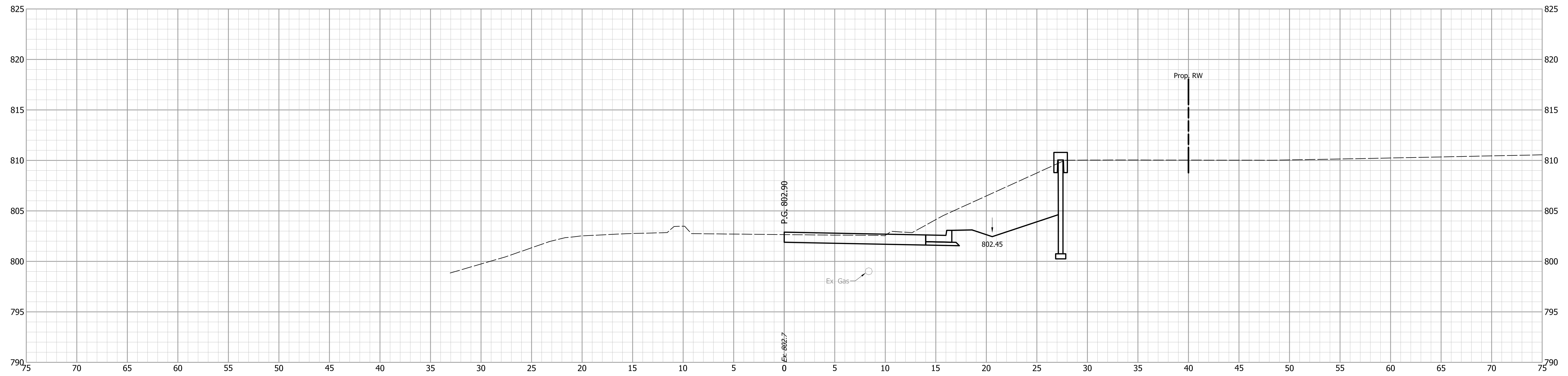

PRELIMINARY PLANS
NOT FOR CONSTRUCTION

59+50

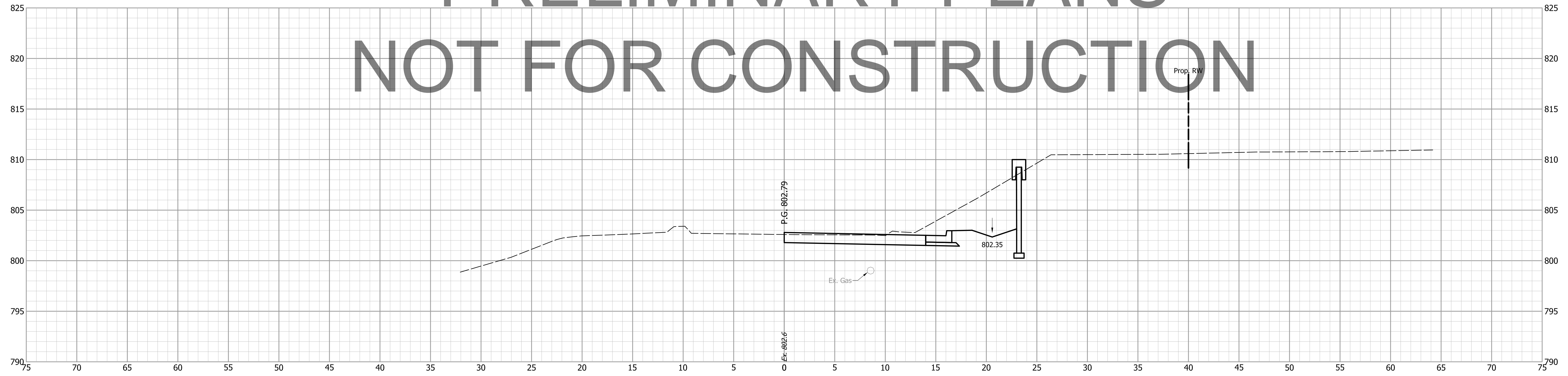

NOT FOR CONSTRUCTION

DESIGNED: _____	PEC	DRAWN: _____	PEC
CHECKED: _____	GRW	CHECKED: _____	GRW

**INDIANA
DEPARTMENT OF TRANSPORTATION**

**CROSS SECTIONS
LINE "F"**

HORIZONTAL SCALE 1" = 5'	BRIDGE FILE
VERTICAL SCALE 1" = 5'	DESIGNATION 1801912
SURVEY BOOK	SHEETS
CONTRACT B-41844	113 of 128 PROJECT 1801912

61+00

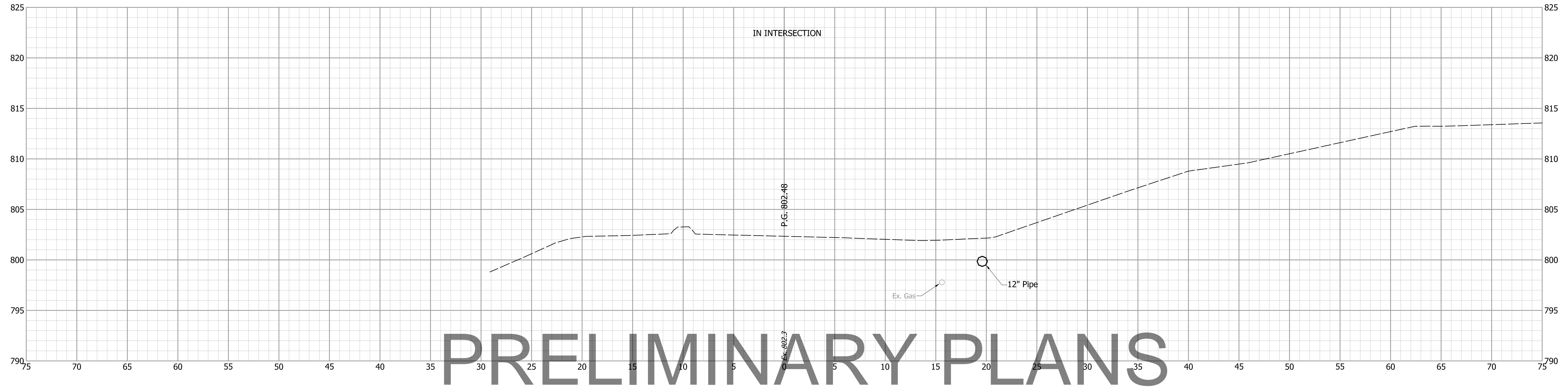

PRELIMINARY PLANS
NOT FOR CONSTRUCTION

60+50

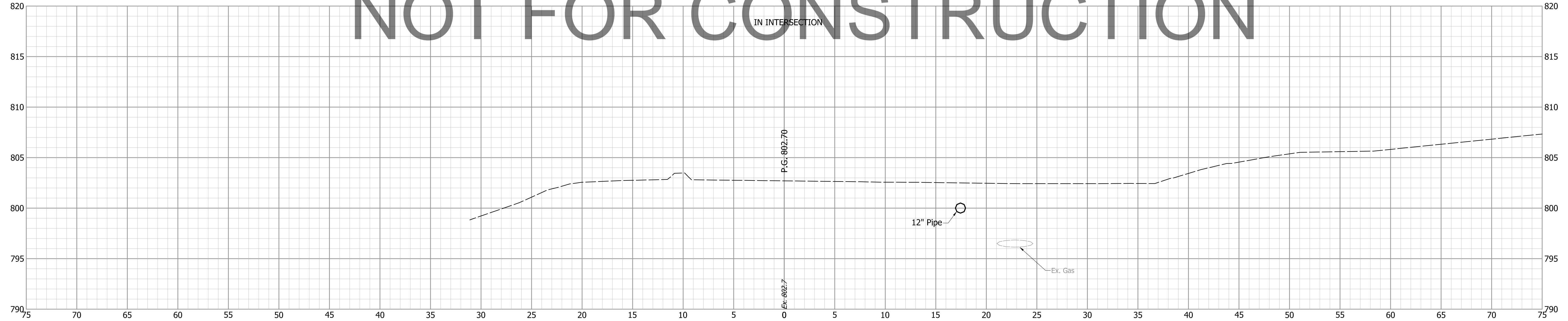

**NOT FOR
CONSTRUCTION**

DESIGNED: _____	PEC	DRAWN: _____	PEC
CHECKED: _____	GRW	CHECKED: _____	GRW

**INDIANA
DEPARTMENT OF TRANSPORTATION**

**CROSS SECTIONS
LINE "F"**

HORIZONTAL SCALE 1" = 5'	BRIDGE FILE
VERTICAL SCALE 1" = 5'	DESIGNATION 1801912
SURVEY BOOK	SHEETS
CONTRACT B-41844	114 of 128 PROJECT 1801912

64+00

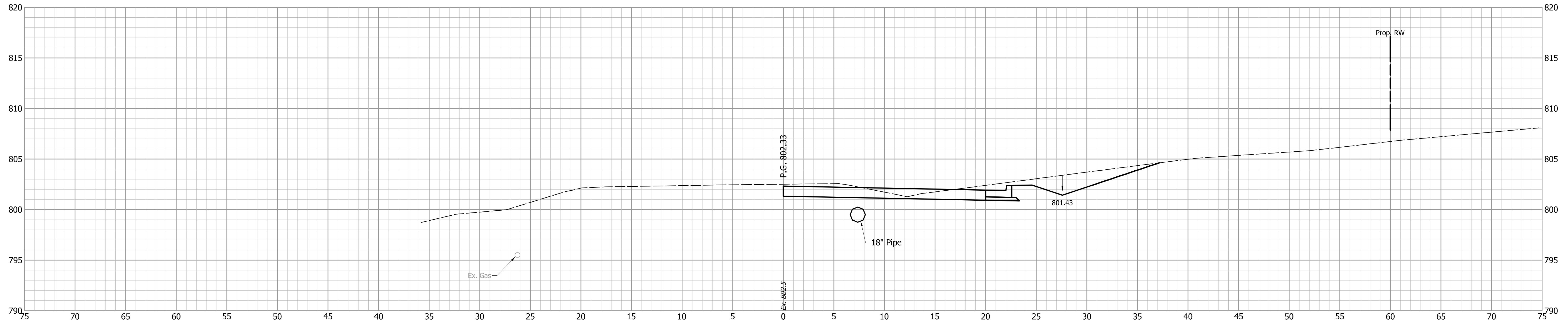

63+54

PRELIMINARY PLANS NOT FOR CONSTRUCTION

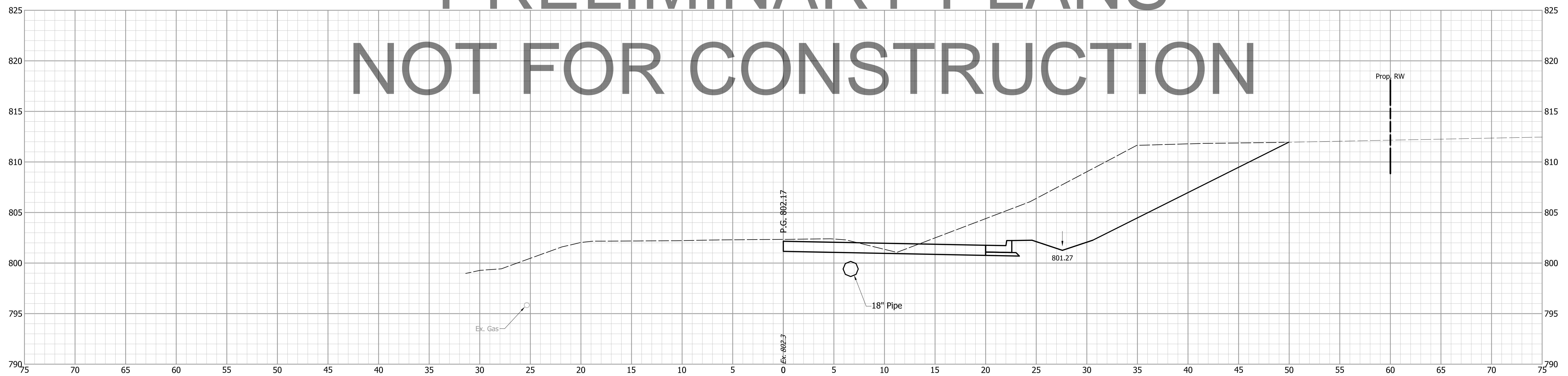

NOT FOR CONSTRUCTION

DESIGNED: _____ PEC DRAWN: _____ PEC
 CHECKED: _____ GRW CHECKED: _____ GRW

**INDIANA
DEPARTMENT OF TRANSPORTATION**

**CROSS SECTIONS
LINE "F"**

HORIZONTAL SCALE 1" = 5'	BRIDGE FILE
VERTICAL SCALE 1" = 5'	DESIGNATION 1801912
SURVEY BOOK	SHEETS
CONTRACT B-41844	119 of 128 PROJECT 1801912

65+00

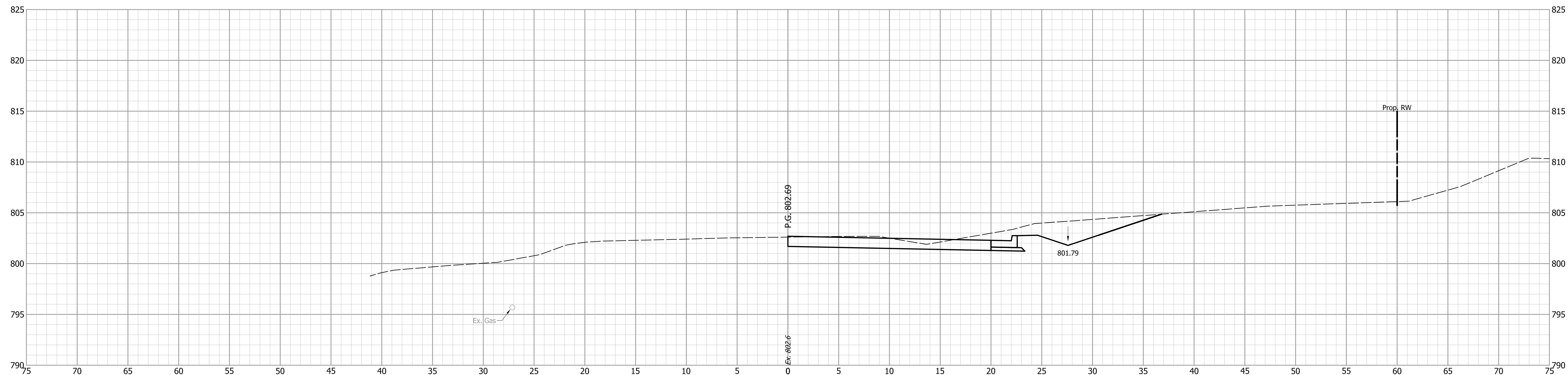

64+50

**PRELIMINARY PLANS
NOT FOR CONSTRUCTION**

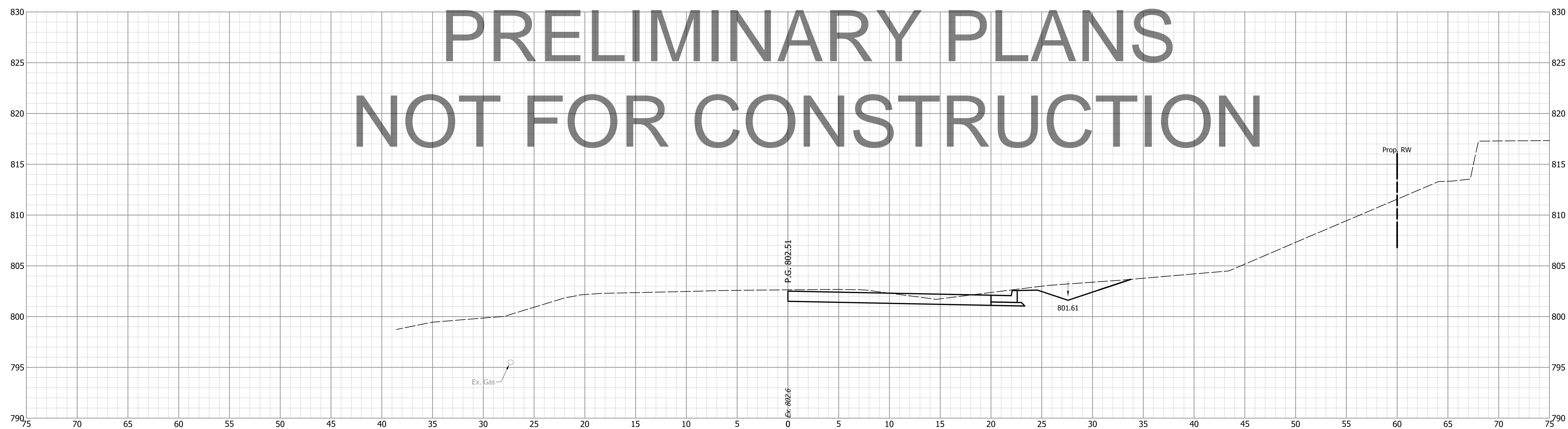

**NOT FOR
CONSTRUCTION**

DESIGNED: PEC DRAWN: PEC
CHECKED: GRW CHECKED: GRW

**INDIANA
DEPARTMENT OF TRANSPORTATION**

**CROSS SECTIONS
LINE "F"**

HORIZONTAL SCALE 1" = 5'	BRIDGE FILE
VERTICAL SCALE 1" = 5'	DESIGNATION 1801912
SURVEY BOOK	SHEETS
CONTRACT B-41844	120 of 128 PROJECT 1801912

66+00

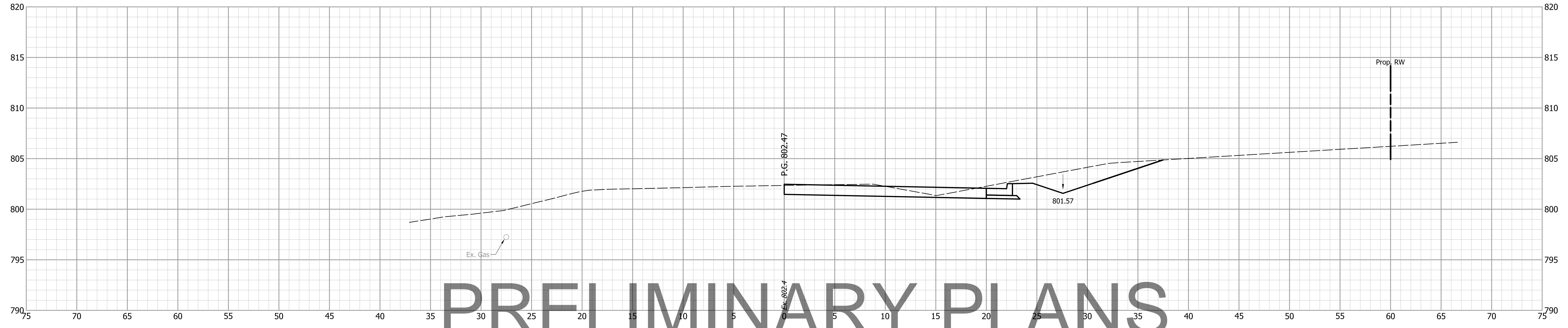

PRELIMINARY PLANS
NOT FOR CONSTRUCTION

65+50

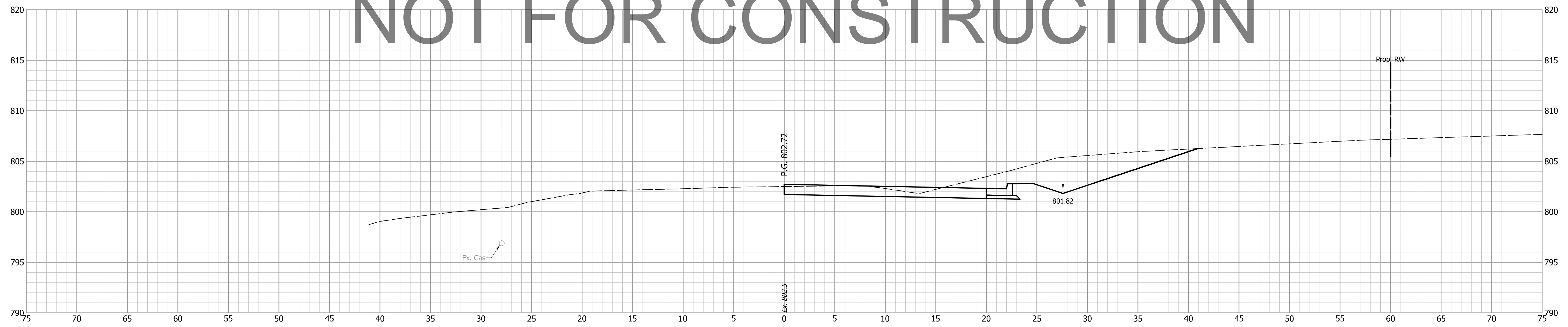

NOT FOR
CONSTRUCTION

DESIGNED: _____ PEC	DRAWN: _____ PEC
CHECKED: _____ GRW	CHECKED: _____ GRW

**INDIANA
DEPARTMENT OF TRANSPORTATION**

**CROSS SECTIONS
LINE "F"**

HORIZONTAL SCALE 1" = 5'	BRIDGE FILE
VERTICAL SCALE 1" = 5'	DESIGNATION 1801912
SURVEY BOOK	SHEETS
CONTRACT B-41844	121 of 128 PROJECT 1801912

66+70

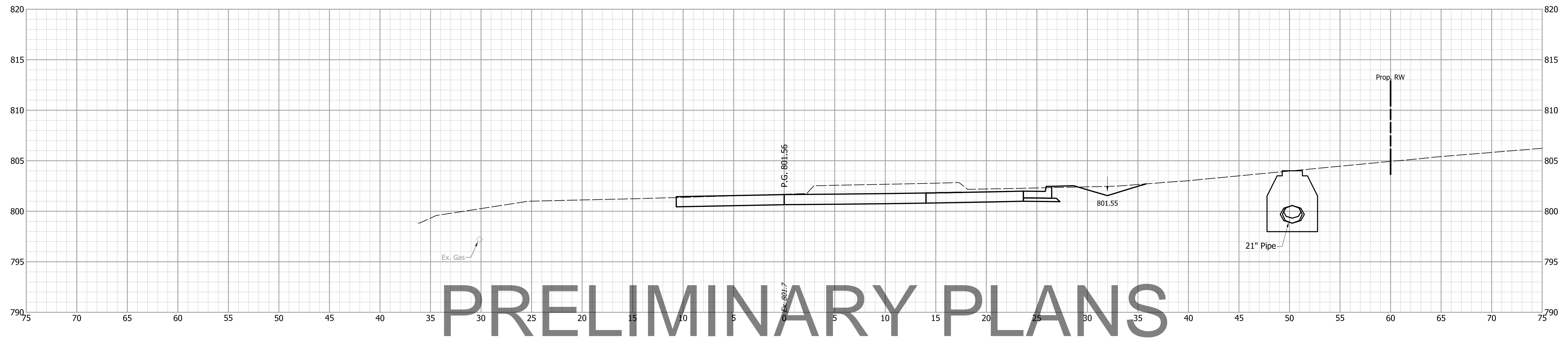

PRELIMINARY PLANS
NOT FOR CONSTRUCTION

66+50

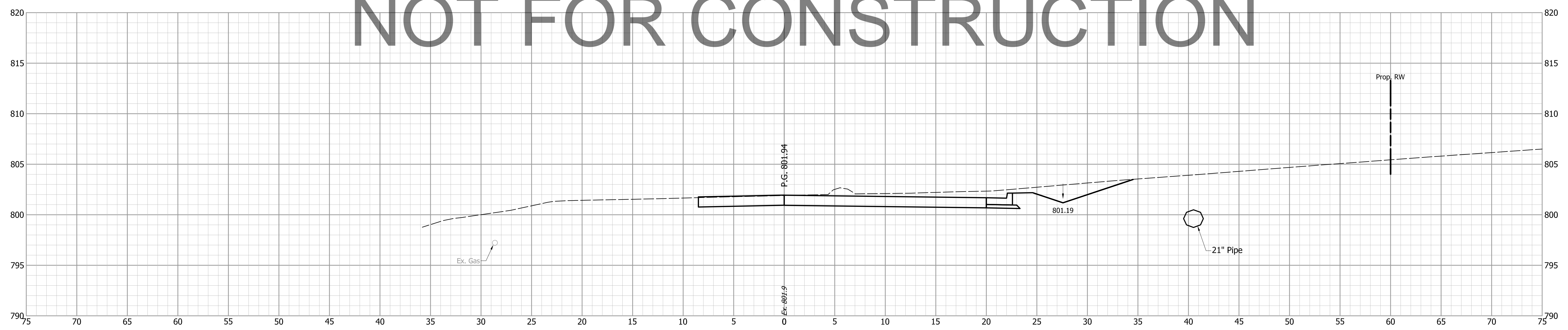

NOT FOR CONSTRUCTION

DESIGNED: _____	PEC	DRAWN: _____	PEC
CHECKED: _____	GRW	CHECKED: _____	GRW

INDIANA
DEPARTMENT OF TRANSPORTATION

CROSS SECTIONS
LINE "F"

HORIZONTAL SCALE	BRIDGE FILE
1" = 5'	
VERTICAL SCALE	DESIGNATION
1" = 5'	1801912
SURVEY BOOK	SHEETS
	123 of 128
CONTRACT	PROJECT
B-41844	1801912

67+50

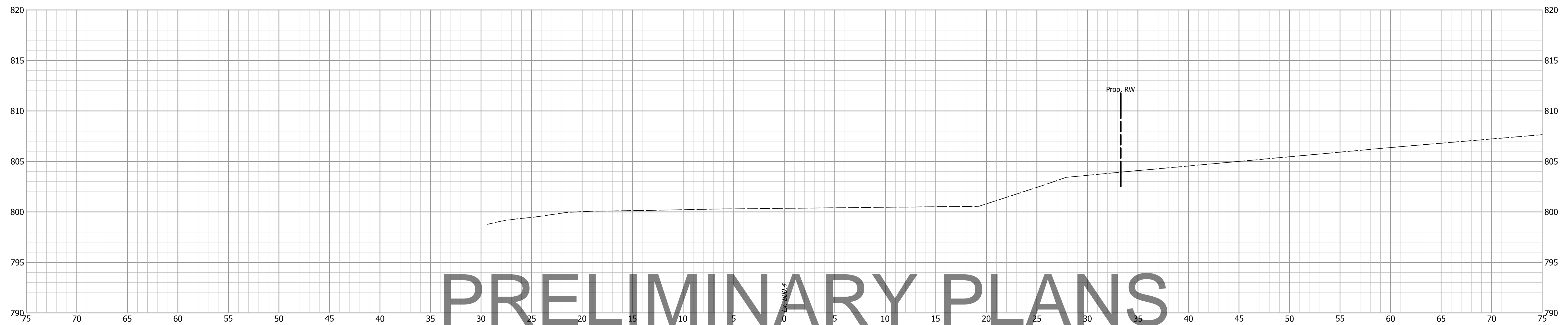

PRELIMINARY PLANS
NOT FOR CONSTRUCTION

END CONSTRUCTION
STA. 67+23.52 LINE "F"

67+00

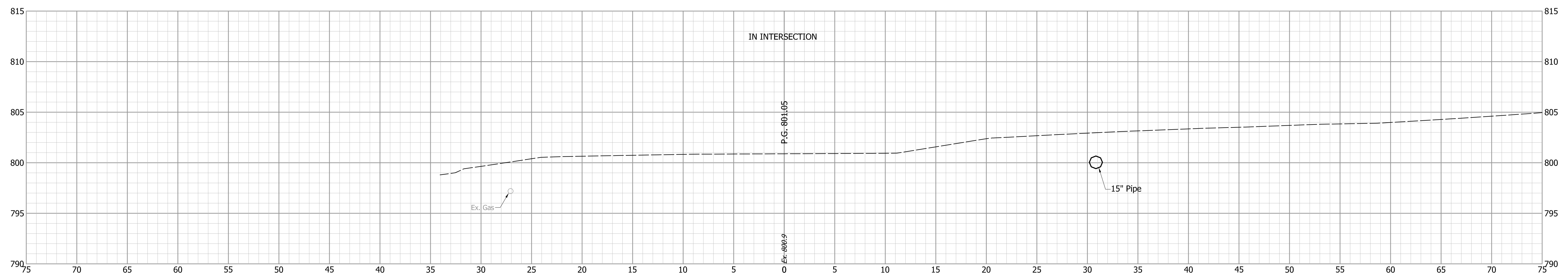

NOT FOR
CONSTRUCTION

DESIGNED: _____ PEC DRAWN: _____ PEC
 CHECKED: _____ GRW CHECKED: _____ GRW

INDIANA
DEPARTMENT OF TRANSPORTATION

CROSS SECTIONS
LINE "F"

HORIZONTAL SCALE 1" = 5'	BRIDGE FILE
VERTICAL SCALE 1" = 5'	DESIGNATION 1801912
SURVEY BOOK	SHEETS
CONTRACT B-41844	124 of 128 PROJECT 1801912

16+00

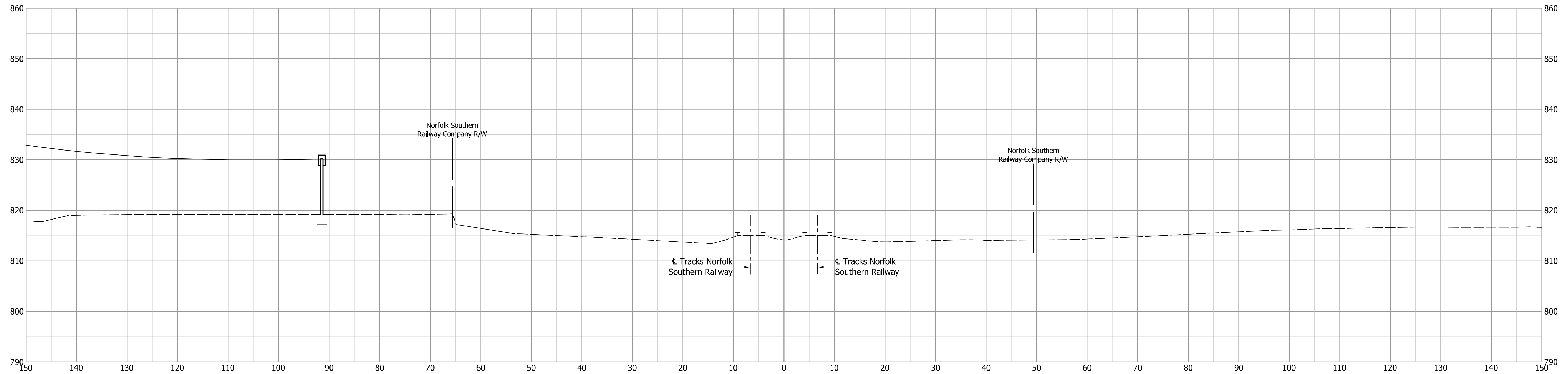

PRELIMINARY PLANS

15+85

NOT FOR CONSTRUCTION

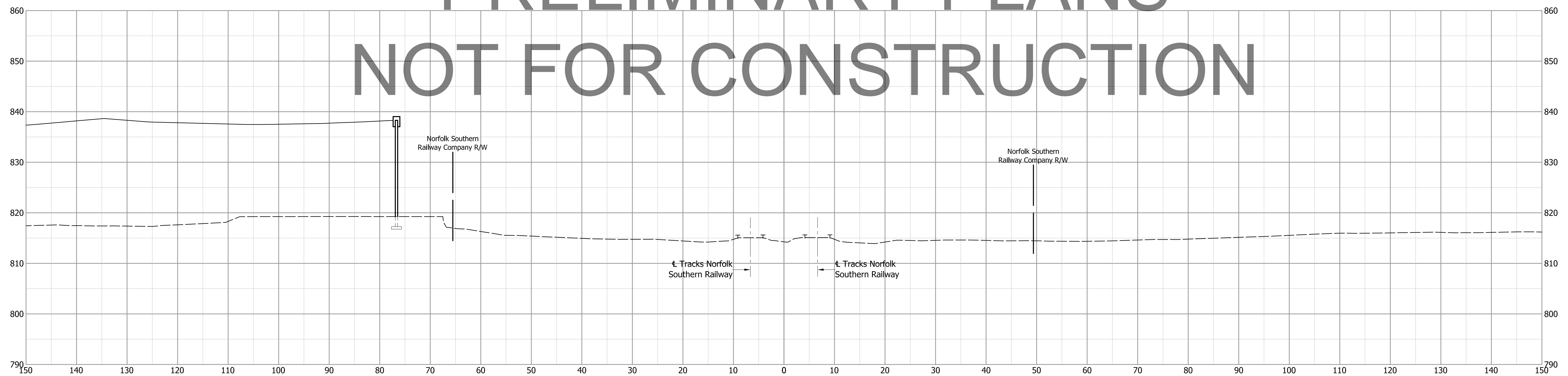

NOT FOR CONSTRUCTION

DESIGNED: _____ PEC DRAWN: _____ PEC
 CHECKED: _____ GRW CHECKED: _____ GRW

INDIANA
 DEPARTMENT OF TRANSPORTATION
 CROSS SECTIONS
 LINE "RR"

HORIZONTAL SCALE 1" = 10'	BRIDGE FILE
VERTICAL SCALE 1" = 10'	DESIGNATION 1801912
SURVEY BOOK	SHEETS 127 of 128
CONTRACT B-41844	PROJECT 1801912

